

# LASE

Industrielle Lasertechnik GmbH



# The company LASE is a system house for Laser measurement technology



## Company data LASE GmbH

- Founded in 1990
- Location Wesel (head office) and Bremen (development department)
- Offices Shanghai (China), Kolkata (India)
- World wide distributor network
- Main business lines
  - *Steel Industry (70%)*
  - *Bulk material handling -mining, power plant)- (20%)*
  - *Port handling machines (10%)*

## Products:

- **1D- 2D- and 3D-** Laser measurement systems, 3D-Camera- and Radar solutions
- **System solutions** (turn key solution provider, with Laser, Software, mechanical and electrical construction, building, mounting, commissioning, training and documentation)



# Product range – laser system components

## 1D-measurement



## 2D-measurement

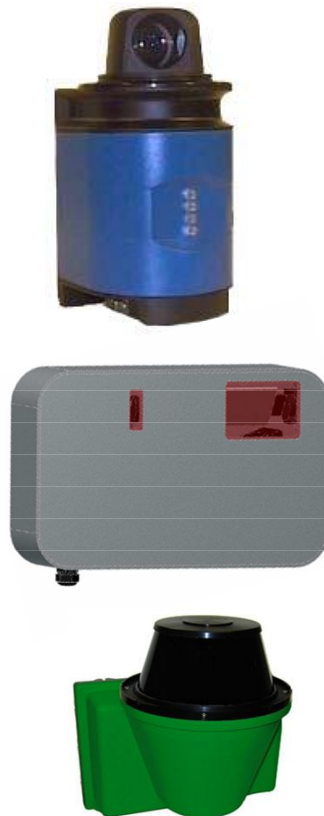

## 3D-measurement



# Product portfolio – 1D laser sensors



## Time of flight principle

Long range market



LASE 1000D-X

## Triangulation principle

Short range market



LASE 1000T  
Greenline



LASE 1000T  
Blackline



LASE 1000T  
Greyline



## 1D - Measurement

Functional principle laser distance meter (Time of Flight System)

**LASE**  
Industrielle Lasertechnik GmbH



### New Generation for Laser Distance Measurement, the „LASE 1000D-X“

- Ranges of up to 800 m with a reflector and up to 120 m on natural surface
- High accuracy 1mm
- High resolution 0,1mm
- Measuring frequency 20 kHz
- Laser Pointer for the adjustment
- All industrial Interfaces integrated
- Optional with special protection housing (e.g. cooling, heating)



## 1D - Measurement

### Functional principle laser distance meter (Triangulation systems)

#### Black line

- Ranges from 4 mm to 700 mm
- Accuracy of 0.5 to 500  $\mu\text{m}$
- surface temperature till 2200°C

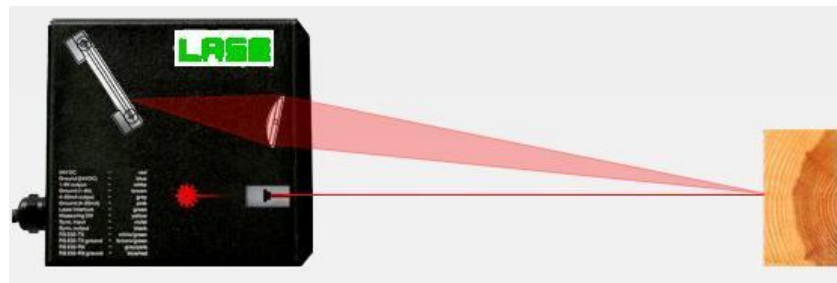

#### Green line

- Ranges from 100 – 2000 mm
- Accuracy of 10 – 500  $\mu\text{m}$
- surface temperature till 2200°C

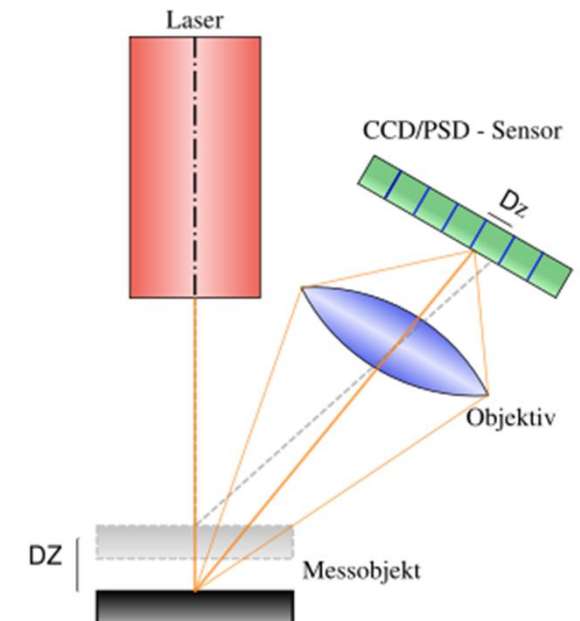

# 1D - measurement

## Examples laser distance meter (Triangulation systems)

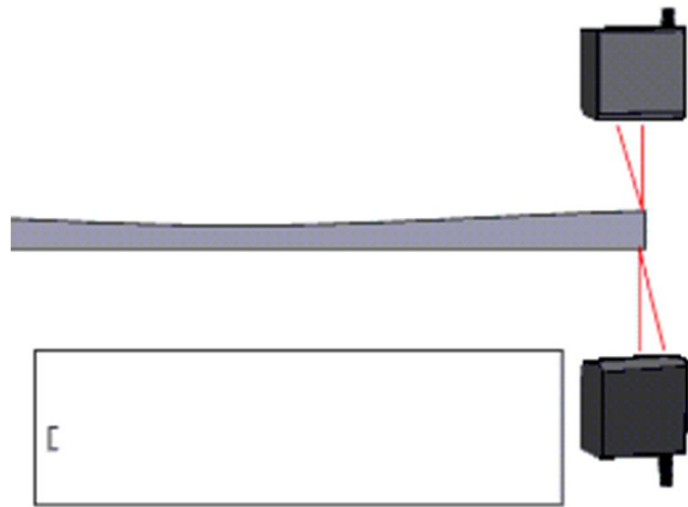
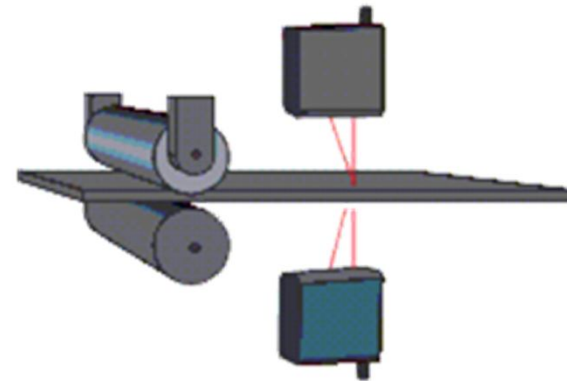
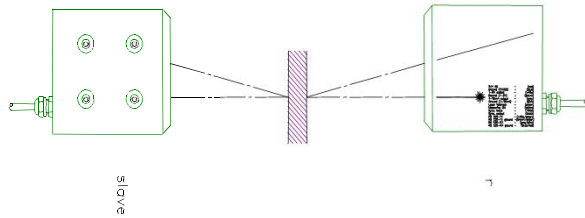

# 2D - measurement

## Functional principle laser distance meter (Triangulation systems)

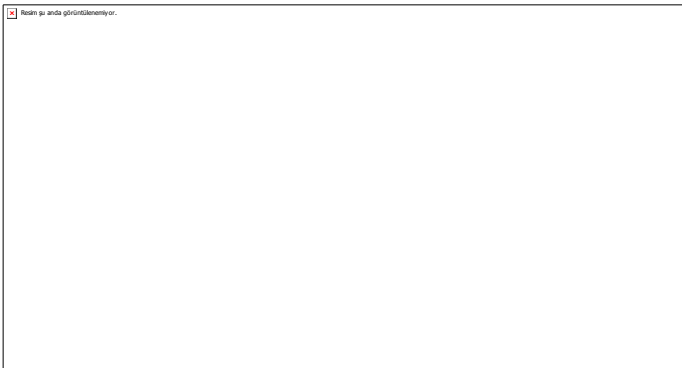
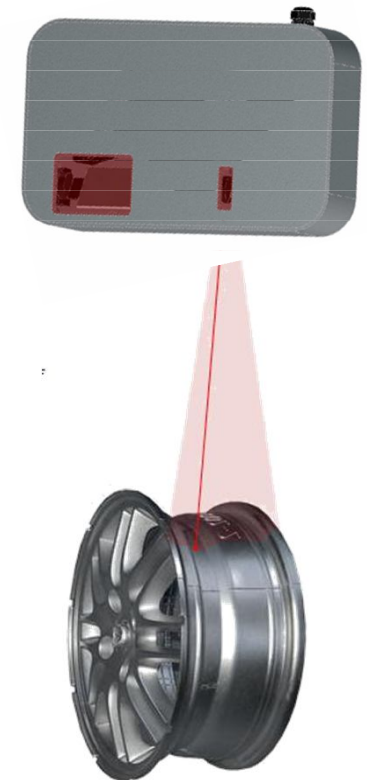
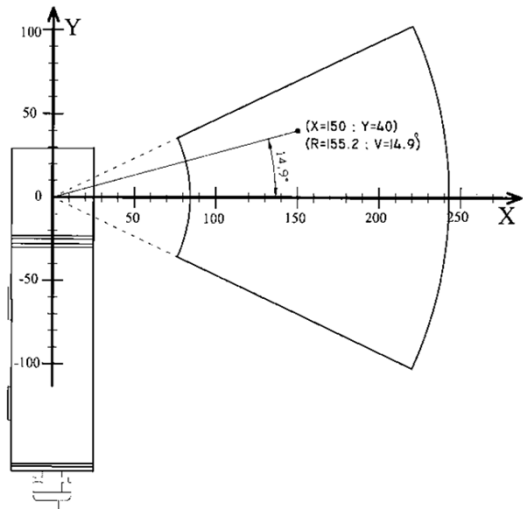

## 2D - measurement

Functional principle laser distance meter (Time of Flight System)

**LASE**  
Industrielle Lasertechnik GmbH

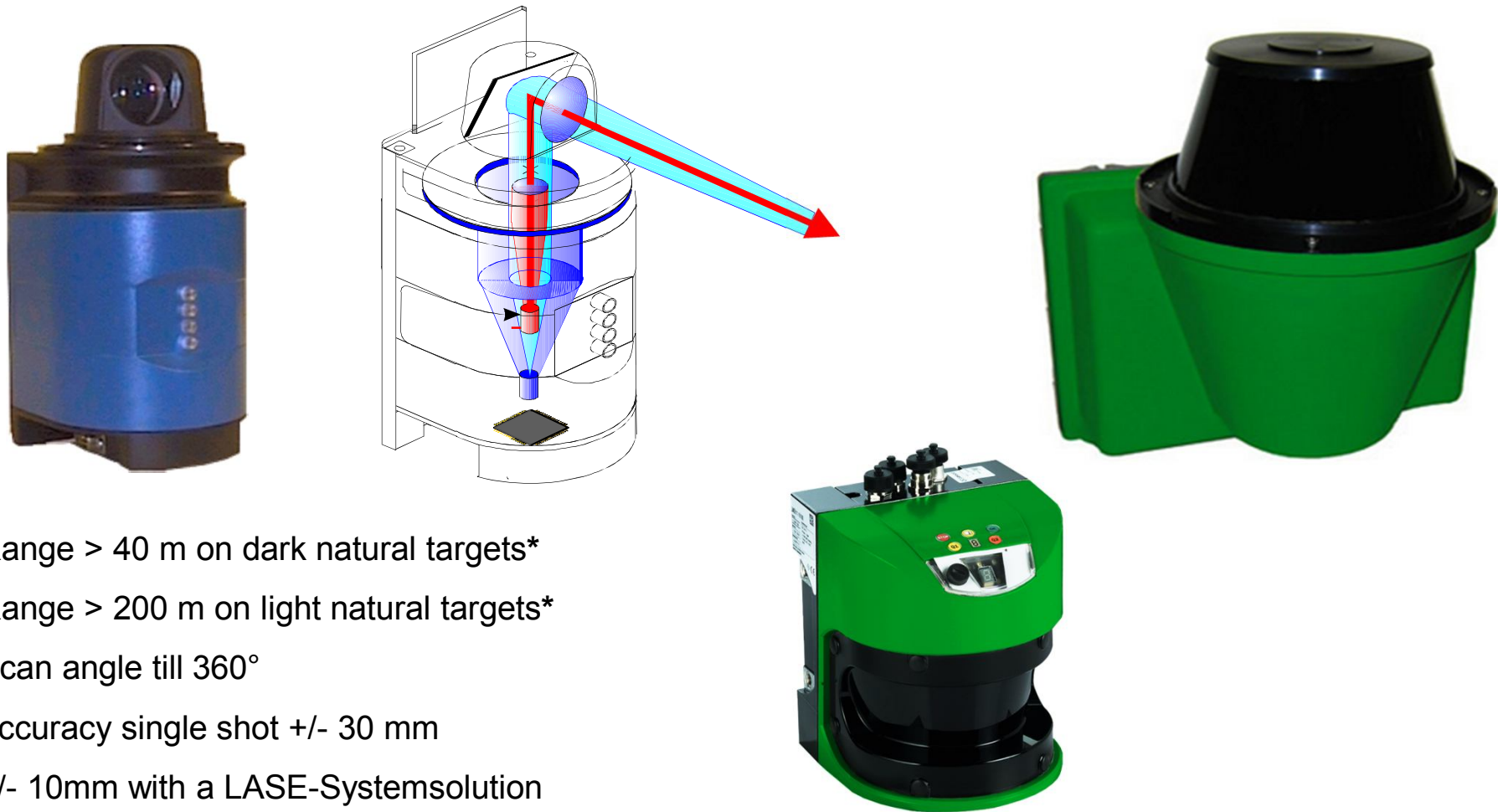

- Range > 40 m on dark natural targets\*
- Range > 200 m on light natural targets\*
- Scan angle till 360°
- Accuracy single shot +/- 30 mm
- +/- 10mm with a LASE-Systemsolution

\* depends from the Laser scanner type

## 3D - Measurement

Functional principle laser distance meter (Time of Flight System)  
in Combination with a Swivel-Platform

**LASE**  
Industrielle Lasertechnik GmbH

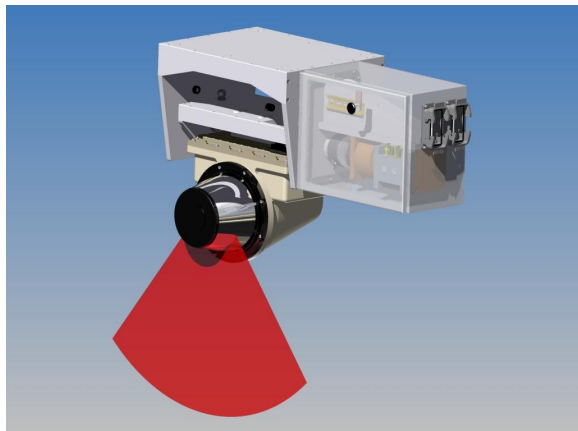
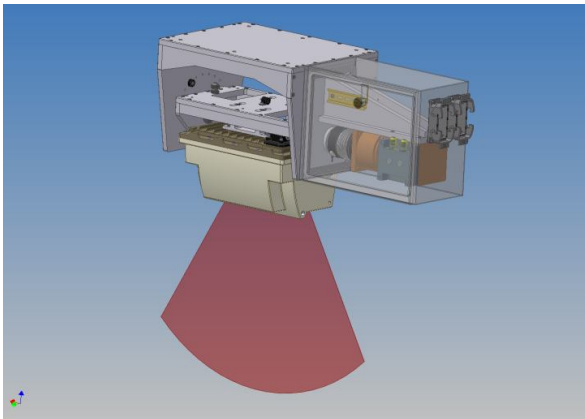

- Range > 80 m on dark natural targets \*
- Range > 250 m on light natural targets \*
- Accuracy single shot +/- 30 mm,  
with a LASE-Systemsolution is  
+/- 10mm possible

\* depends from the lasertype



# LASE can provide

Scope of delievery LASE

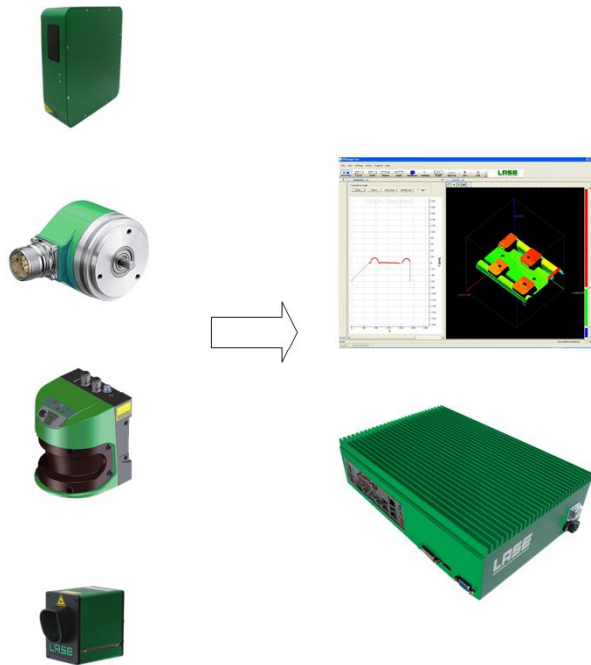

Sensor

Hardware/Software

Customer



PLC or Level 2

**LASE System Solutions using:**

**CEWS** *Framework*

# CEWS Framework:



## Included Filter Algorithms:

- Definition of Region of Interest
- Blind-Out Areas
- Elimination of Invalid Measurement Points
- Dust / Rain Filter
- Average Calculations
- Segmentation (Object Detection)
- Filling Functions
- Div. Project Specific Filter (e.g. Edge Detection, Volume Determination, Velocity Measurement etc.)

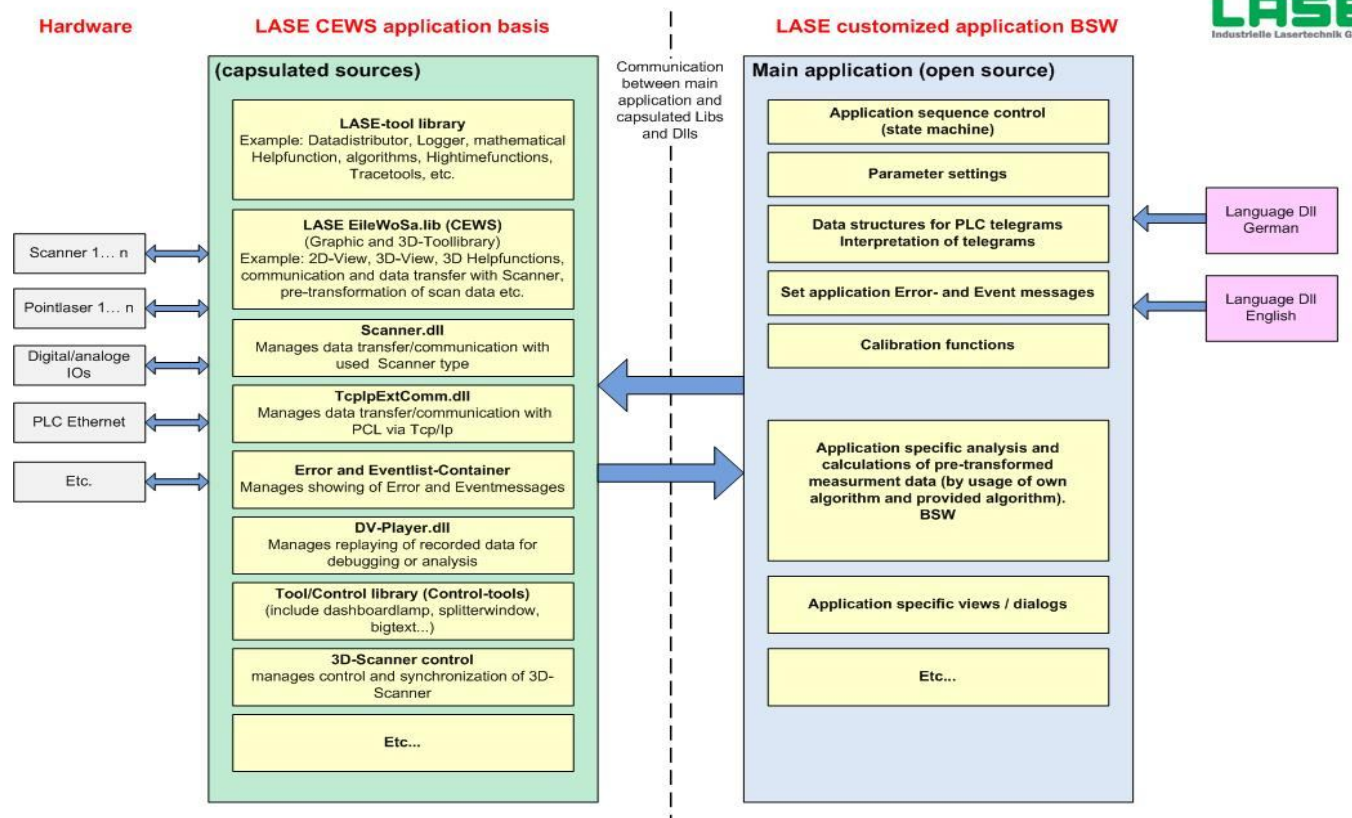

# CEWS Diagnostics & Service

**LASE**  
Industrielle Lasertechnik GmbH

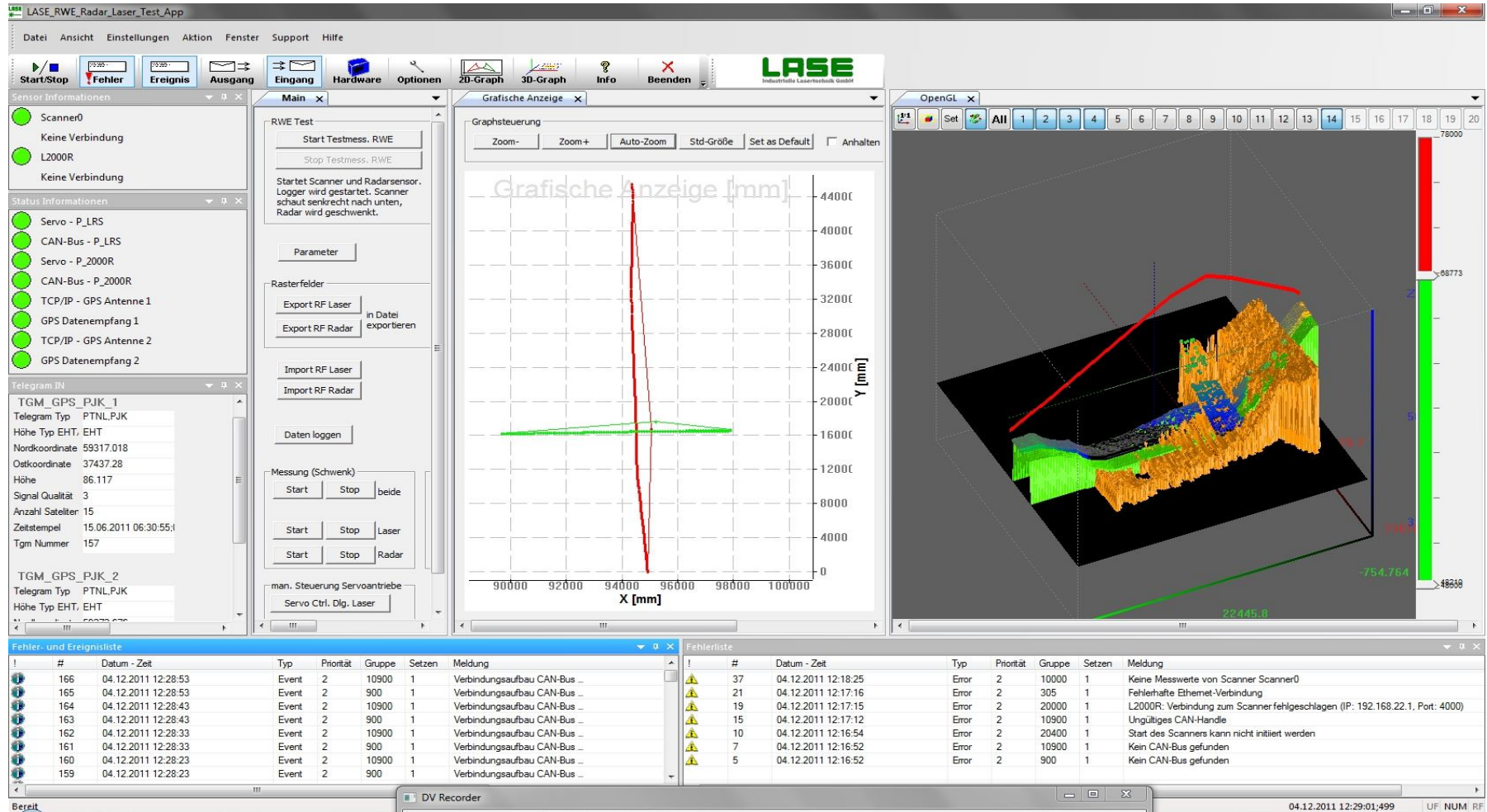

Screenshot of a typical LASE application

# CEWS Diagnostic & Service

Byte- No.□	length- [Bytes]□	format□	unit□	description□
0□	44□	□	□	Telegram header□
44□	4□	DWORD□	□	Machine ID number□
48□	4□	DWORD□	Bit□	Application Status (just 1 Bit per time is set!)□
				0□ 1 = IDLE (App. is ready to start measurements)□
				1□ 1 = PREPARE□
				2□ 1 = MEASUREMENT ACTIVE□
				3□ 1 = MAINTENANCE□
				4□ 1 = ERROR□
				5□ 1 = CALIBRATION□
				6□ Reserve□
7□ Reserve□				
52□	4□	DWORD□	Bit□	Measurement Task (just 1 Bit per time is set!)□
				0□ 1 = Task 1 (See description above)□
				1□ 1 = Task 2 (See description above)□
				2□ 1 = Task 3 (See description above)□
				3□ 1 = Task 4 (See description above)□
				4□ Reserve□
				5□ Reserve□
				6□ Reserve□

Example Status Telegramm

(all needed telegrams can be defined upon consultation)

56□	4□	DWORD□	Bit□	7□ Reserve□
				Errors/Warning (several Bits per time can be set!)□
				0□ System not calibrated□
				1□ Laser scanner fault□
				2□ Servo drive fault□
				3□ Interface (TCP/IP) error scanner□
				4□ Interface (CAN-Bus) error servo drive□
				5□ Warning – too many invalid measurement points□
6□ Reserve□				
7□ Reserve□				
60□	4□	DWORD□	□	Reserve□
64□	4□	DWORD□	□	Reserve□
68□	4□	DWORD□	□	Reserve□
72□	4□	DWORD□	□	Reserve□
76□	4□	DWORD□	□	Reserve□

# Example Hardware Overview

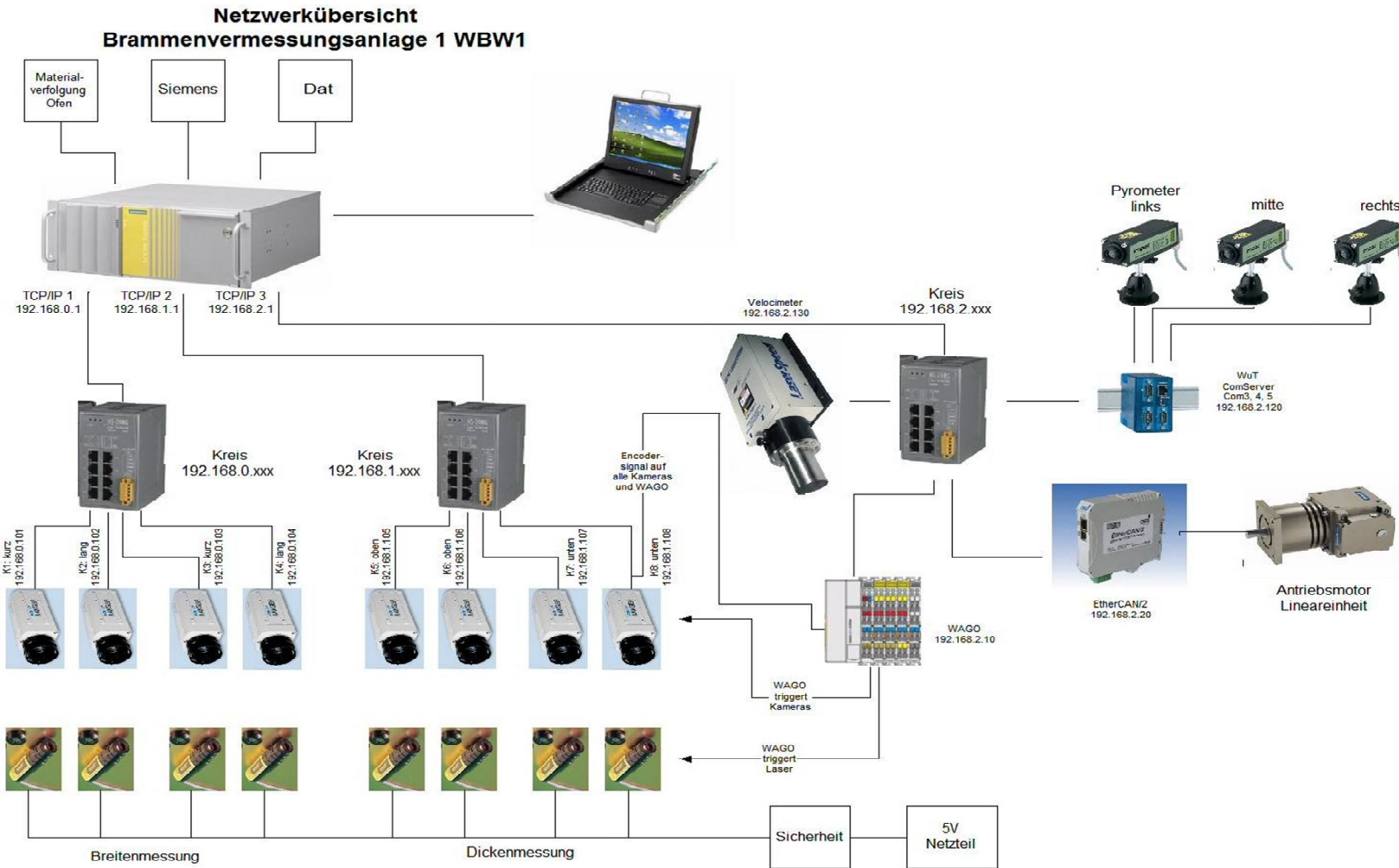



# Steel plant applications - 1D / 2D / 3D



## Automatic ladle transport



**Automatic operation**

**Great savings in time and distance with optimised positioning**

**High functional reliability**

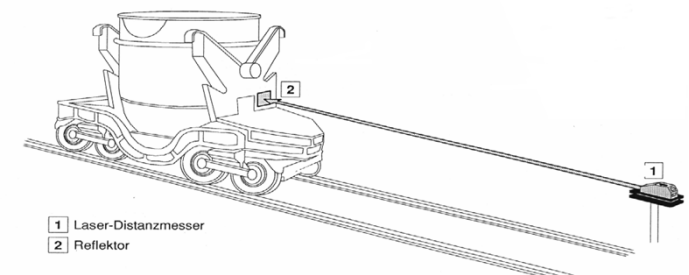

# Steel plant applications - 1D / 2D / 3D



Hot level measurement in ladles

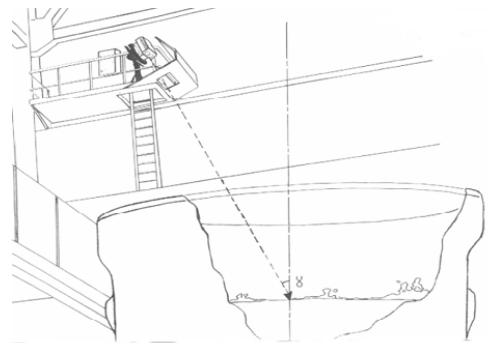

Automatic operation

High Availability

Contactless measurement

Wear measurement in harsh environments

High operational safety and reliability



## Gasometer - 1D

- Control of Gasometer cover movement
- Contactless continuous measurement on the cover for level control
- Range >400 m on reflectors
- High accuracy and resolution
- RS232, RS422, Profi-bus
- Self test, rugged design
- Simple installation in any mounting position
- Optional with explosion protection housing (ex-proof for zone 1 and 2)

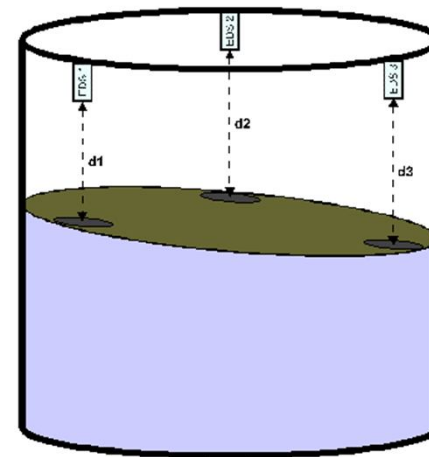

**LASE**  
Industrielle Lasertechnik GmbH

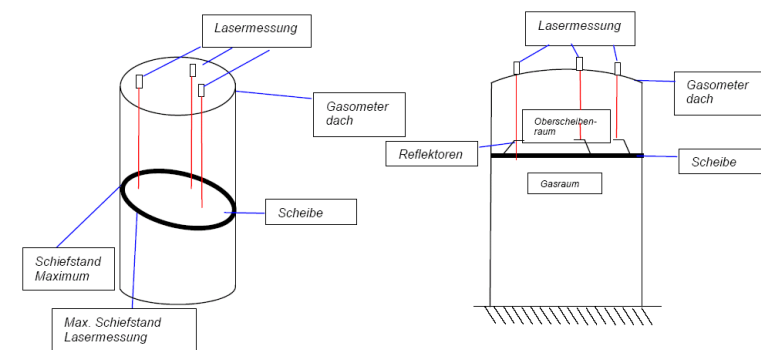



## Positioning crane installation - 1D / 2D / 3D

**LASE**  
Industrielle Lasertechnik GmbH



**3 axis position monitoring**

**Synchronization control**

**Collision avoidance supervision**

**Accuracies up to  $\pm 0,5\text{mm}$**

**High dynamics**

**Ranges of up to 800m**

## Crane position - 1D / 2D

- System for automatic crane
- Automatic picking up and putting down of objects
- Verification of number of objects in the storage field
- System conversation with the warehouse management

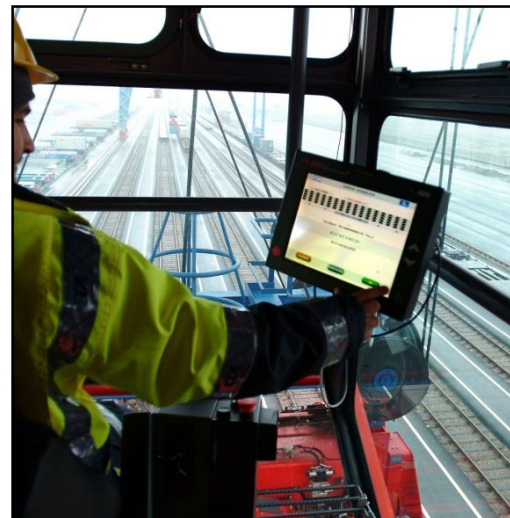

**LASE**  
Industrielle Lasertechnik GmbH





# Crane position - 1D / 2D

## Collision avoidance supervision

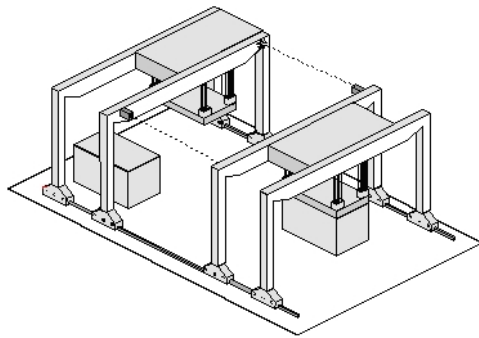

## Crooked run supervision at portal cranes

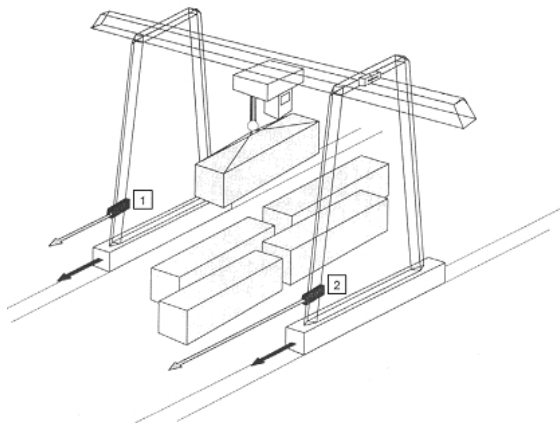



## Slab solutions - 2D / 3D

**LASE**  
Industrielle Lasertechnik GmbH



**Automation of the slab storage**

**Slab measurement**

**Slab positioning**

**Monitoring of slabs  
on the roller table**

**Form detection**

**Positioning of the  
torch cutting machine**

# Slab and billet measurement - 1D / 2D / 3D



- Exact measurement
- Shape (saber, wedge)
- For quality and verification purposes
- Side profile recognition

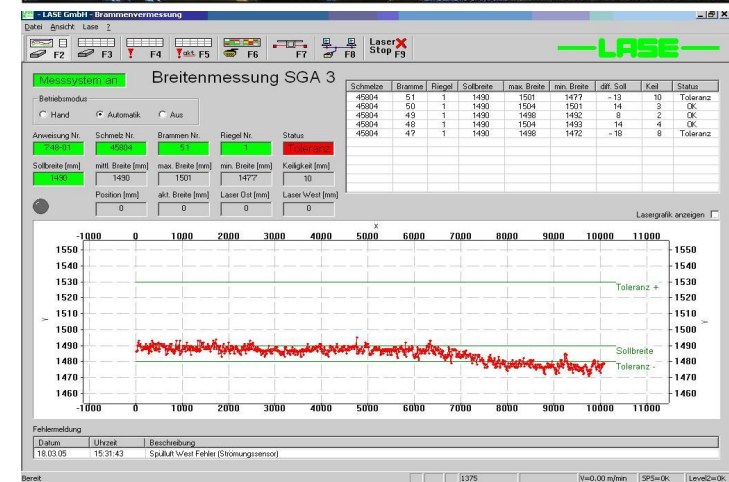
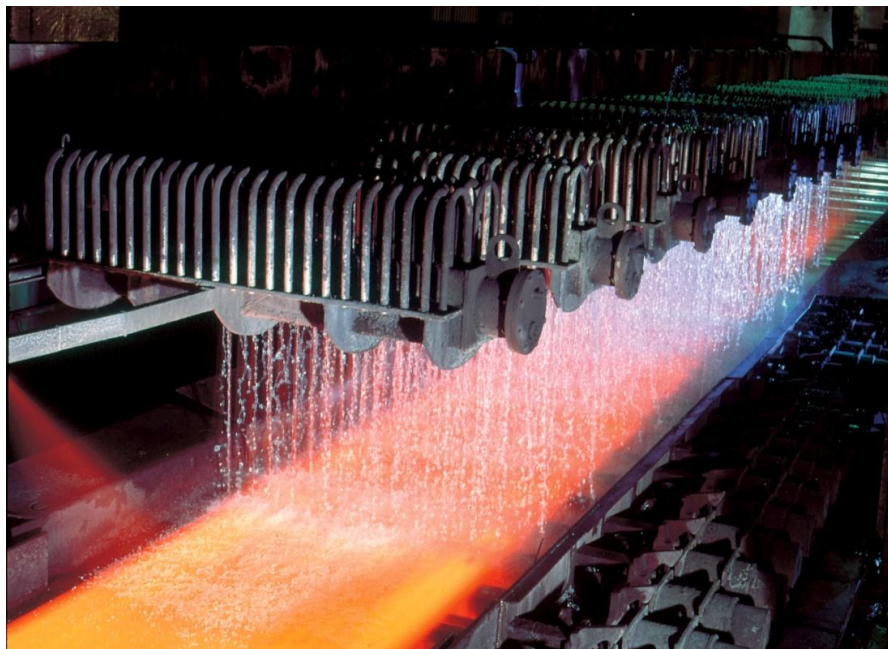



## Continuous casting thickness measurement – 1D

- Calculation of the billet thickness
- Recording of the measuring data
- Calculation of temperature compensation
- Robust design of loading gage

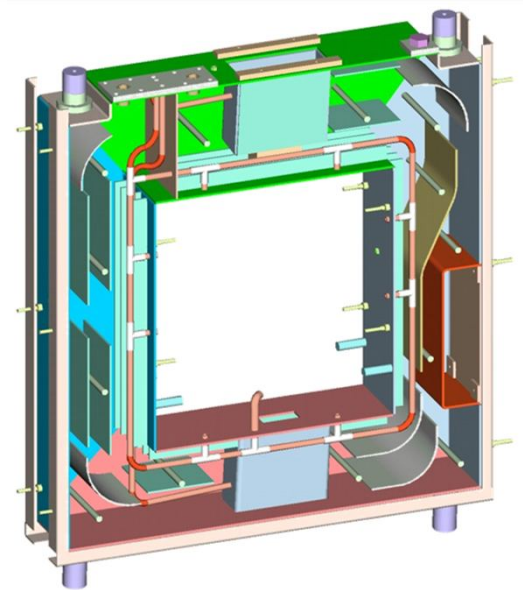
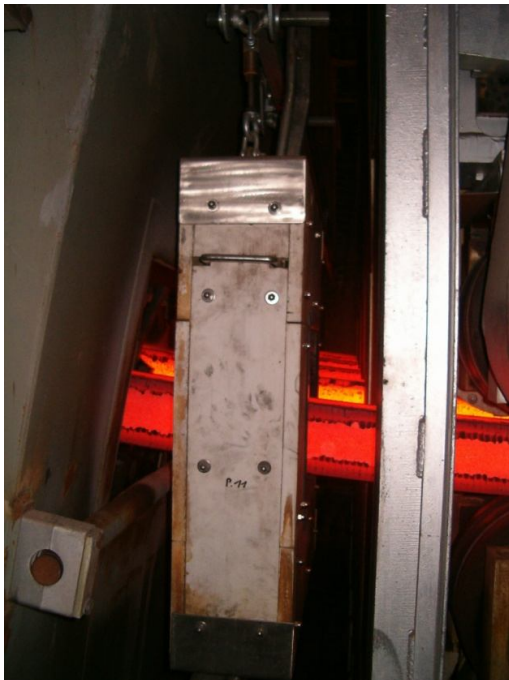

## Slab measurement - 1D / 2D

- Calculation of the max., min., and average width values
- Correction of misalignment
- Calculation of wedge shape and saber shape
- Calculation of a virtual space for the optimal loading of the furnace
- Useable after casting or in front of the furnace

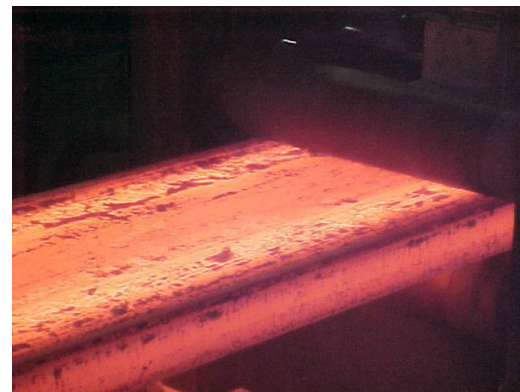
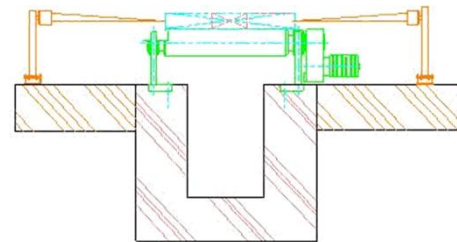

# Slab measurement - 1D / 2D

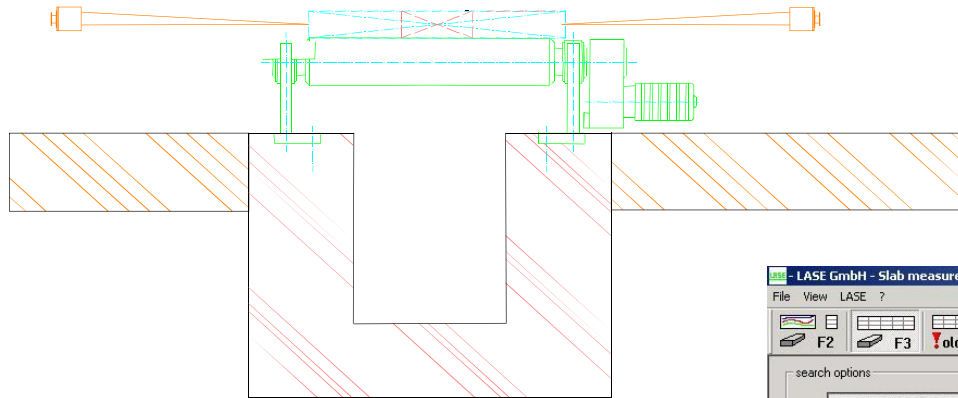

SPS



Control Station

LASE LCU

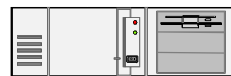

Digital Input



1 x Light Barrier

2 x Laser L1000T-1400



1 x Encoder

LASE GmbH - Slab measurement

File View LASE ?

F2 F3 !old F4 !curr.F5 F6 F7 Laser Stop F8

— LASE — CORUS

search options

current Slabs

Slab Nr.:

search

Start date/time

date: 2/ 4/2005

time: 12:00:00 AM

first entry:

End date/time

date: 2/ 4/2005

time: 12:19:20 PM

last entry:

show at doubleclick on tableentry

dialog error messages

dialog Slabdata

Slab table

date	time	Slab Nr.	declination	nom. Width	aver. Width	max. Width	min. Width	tolerance	nom Length	Length	wedge	status
04.02.05	13:01:22	152533	-298	1600	1607	1612	1603	100	10304	10360	0	OK
04.02.05	13:00:52	152532	-208	1600	1606	1615	1598	100	10300	10327	5	OK
04.02.05	12:57:33	152531	-1001	1600	1566	1584	1510	100	7982	8027	63	OK
04.02.05	12:56:55	152530	-253	1600	1581	1587	1574	100	7986	8033	4	OK
04.02.05	12:53:34	152529	-124	1600	1579	1583	1576	100	7990	8035	-1	OK
04.02.05	12:48:59	152528	-139	1600	1577	1580	1574	100	8020	8083	0	OK
04.02.05	12:44:43	152527	-271	1700	1695	1702	1680	100	10303	10323	8	OK
04.02.05	12:44:06	152526	-1176	1700	1695	1700	1690	100	9185	9235	2	OK
04.02.05	12:43:29	152525	-74	1700	1694	1699	1689	100	10284	10320	-2	OK
04.02.05	12:42:09	152524	-527	1600	1590	1594	1586	100	7997	8041	3	OK
04.02.05	12:41:32	152523	-11	1600	1589	1593	1586	100	8001	8037	1	OK
04.02.05	12:40:56	152522	-1029	1600	1618	1628	1611	100	7984	8006	2	OK
04.02.05	12:40:18	152521	-161	1700	1693	1696	1689	100	10314	10335	-4	OK
04.02.05	12:36:28	152520	-137	1700	1695	1699	1689	100	10298	10330	2	OK
04.02.05	12:34:11	152519	-1692	1700	1697	1703	1690	100	10299	10365	-5	OK
04.02.05	12:33:34	152518	-1666	1700	1694	1698	1690	100	10294	10339	-3	OK
04.02.05	12:32:57	152517	-351	1600	1602	1613	1593	100	11505	10335	7	OK
04.02.05	12:30:22	152516	-76	1700	1708	1712	1703	100	7997	8042	2	OK
04.02.05	12:29:45	152515	-2212	1700	1687	1691	1682	100	8001	8033	-4	OK
04.02.05	12:29:08	152514	-2006	1700	1697	1701	1693	100	7996	8038	0	OK
04.02.05	12:28:31	152513	-1306	1740	1744	1783	1683	100	8007	8047	92	OK
04.02.05	12:24:34	152512	-1899	1700	1686	1690	1684	100	7989	8036	-1	OK
04.02.05	12:23:57	152511	-2066	1700	1686	1690	1684	100	7986	7738	2	BM
04.02.05	12:22:17	152510	-86376	1700	0	0	0	100	9204	0	0	BT/SK/LM/B
04.02.05	12:09:25	1523165	-175	1000	1003	1006	1001	100	7996	8087	1	OK
04.02.05	12:08:49	1523164	-560	1000	958	992	939	100	8001	8090	-33	OK
04.02.05	12:08:15	1523163	-123	950	945	948	938	100	7991	8096	-9	OK
04.02.05	12:06:11	1523162	220	950	985	1013	948	100	7997	8071	60	OK
04.02.05	12:04:25	1523161	-158	1100	1103	1106	1100	100	8002	8029	0	OK
04.02.05	12:03:50	1523160	-141	1100	1103	1107	1100	100	7997	8028	0	OK

ready

912 54



# Slab measurement - 1D / 2D

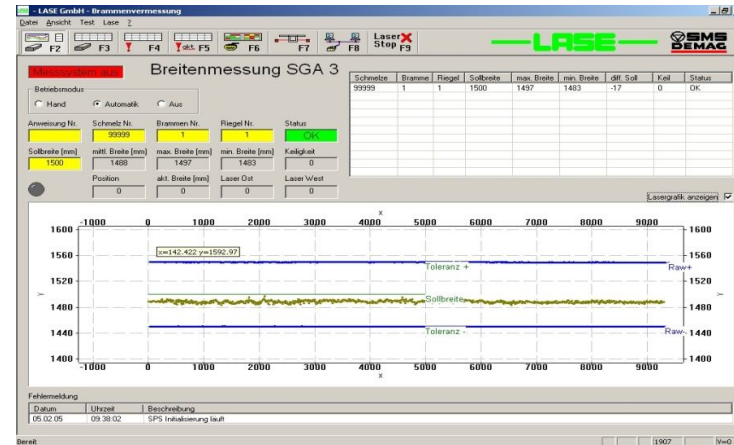
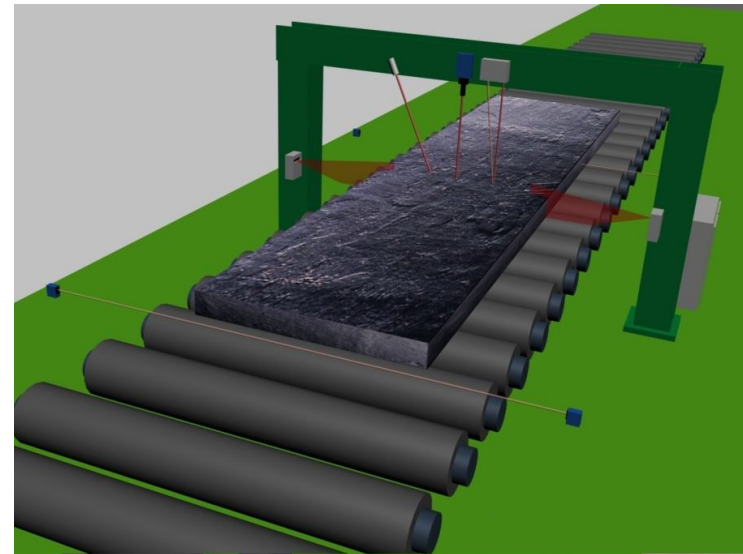
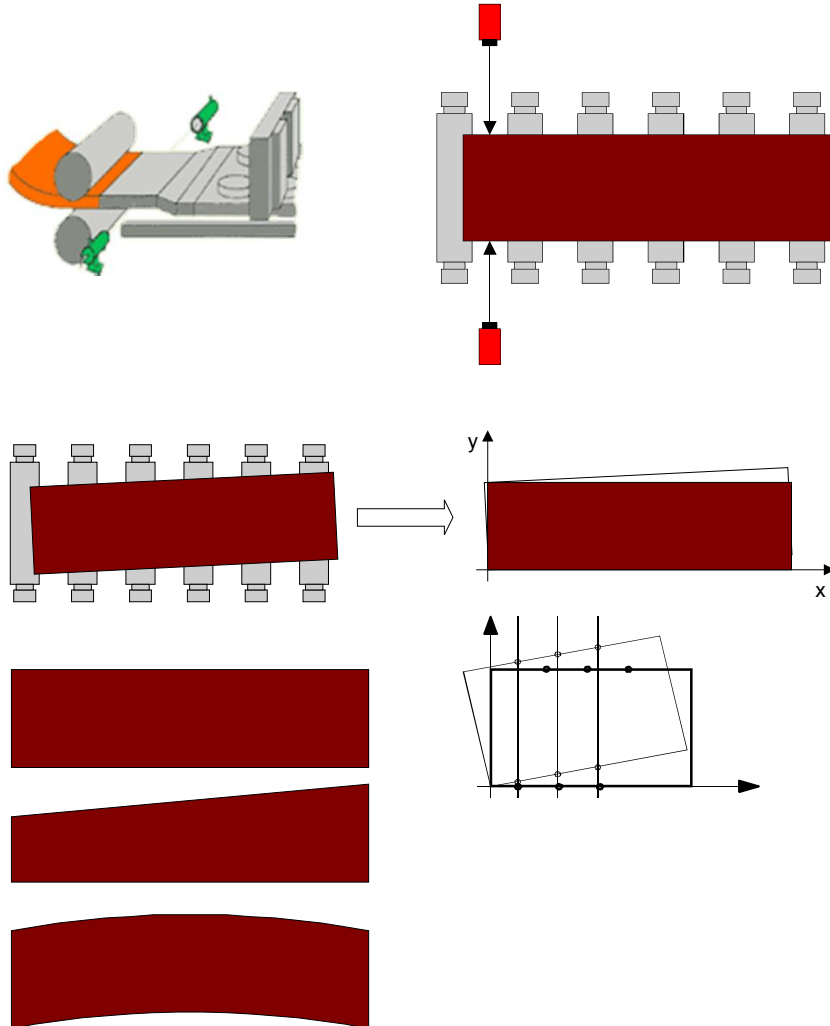



# Slab measurement - 2D / 3D



- Exact measurement of slab contour
- Shape (saber, wedge)
- For quality and verification purposes
- Side profile recognition

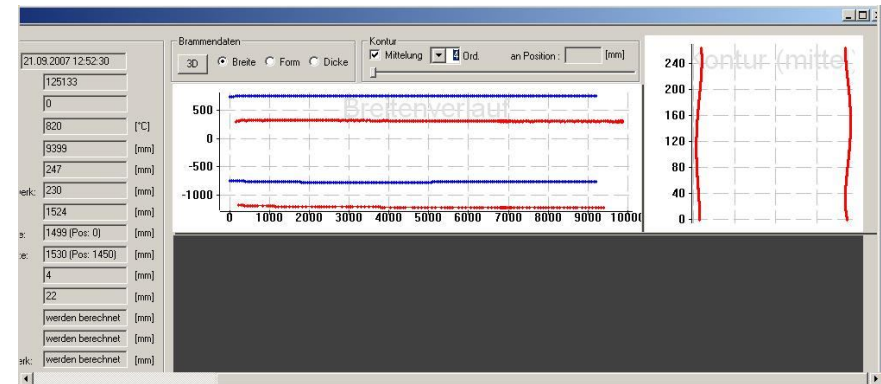
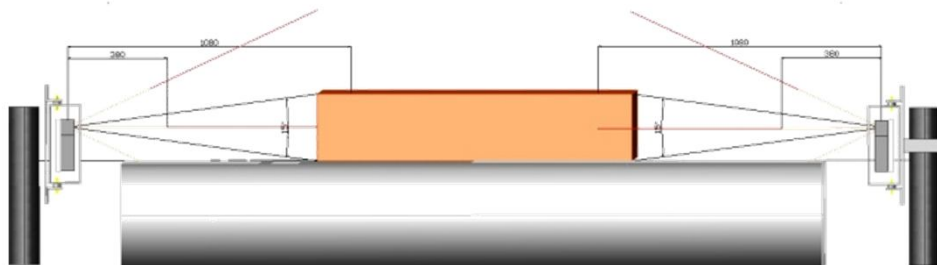

## Slab position measurement - 2D

- Exact position measurement
- Furnace protection
- Contactless measurement
- Save labour cost (when automatic operation)

**LASE**  
Industrielle Lasertechnik GmbH

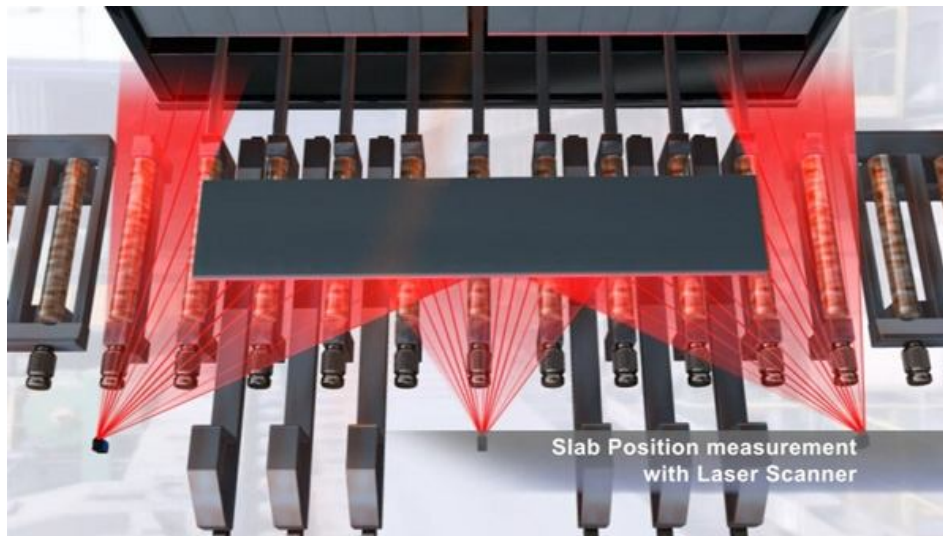
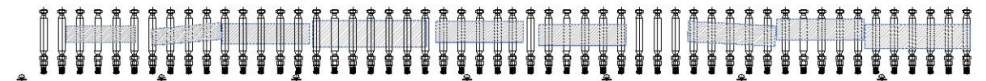
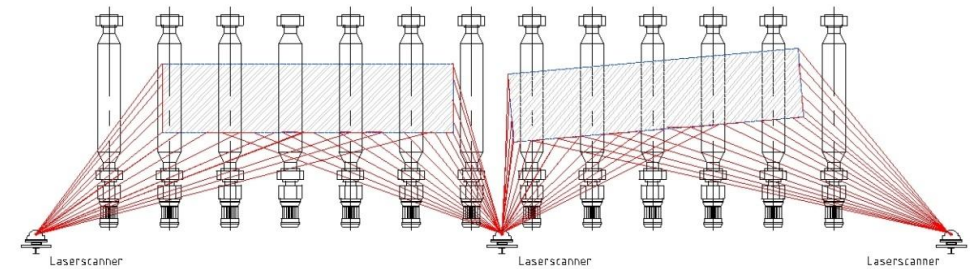

# Slab position measurement - 2D



Material Tracking System



Slab Positioning System



## Measurement Frame - 3D

**LASE**  
Industrielle Lasertechnik GmbH

- Complete profile recognition for long Material (Pipes, Billets, Beams, sheet pile wall, etc.)
- Exact measurement of dimensions, with a very high accuracy and high speed
- useable for surface detection
- For quality and verification purposes

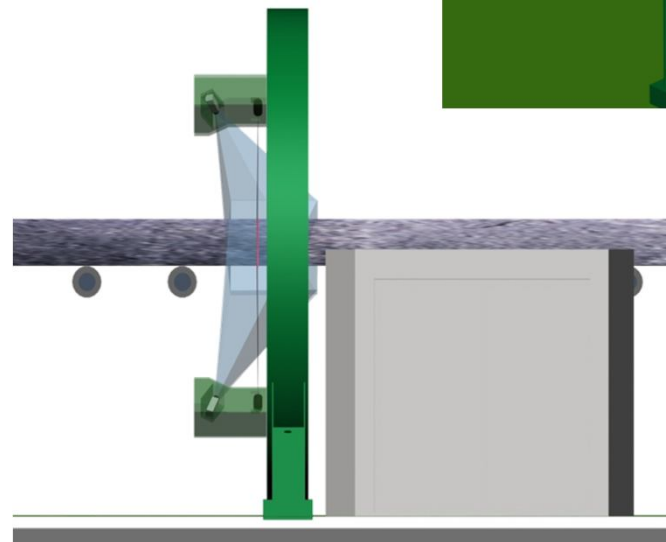
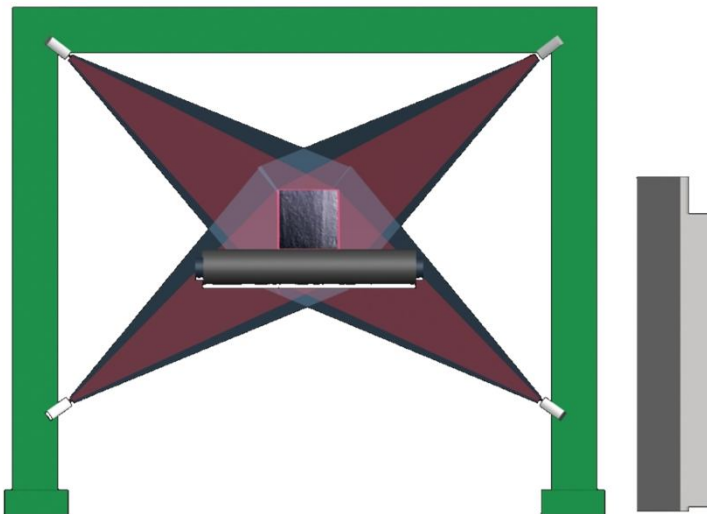
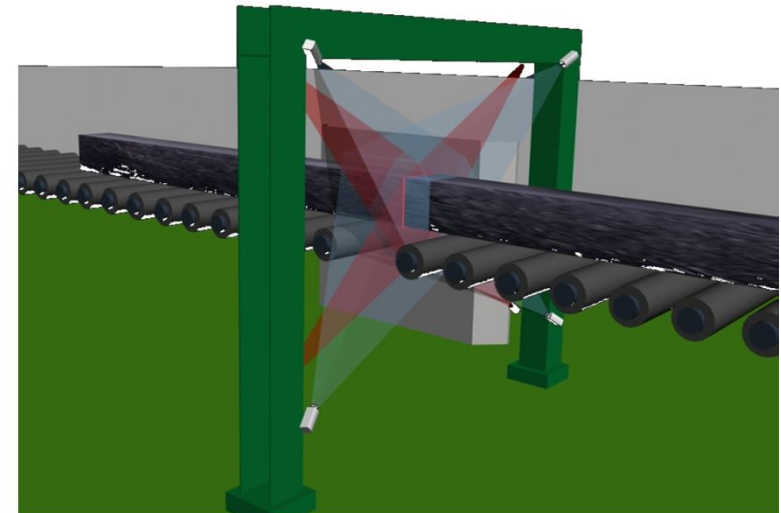



# Billet / Rounds solution - 3D

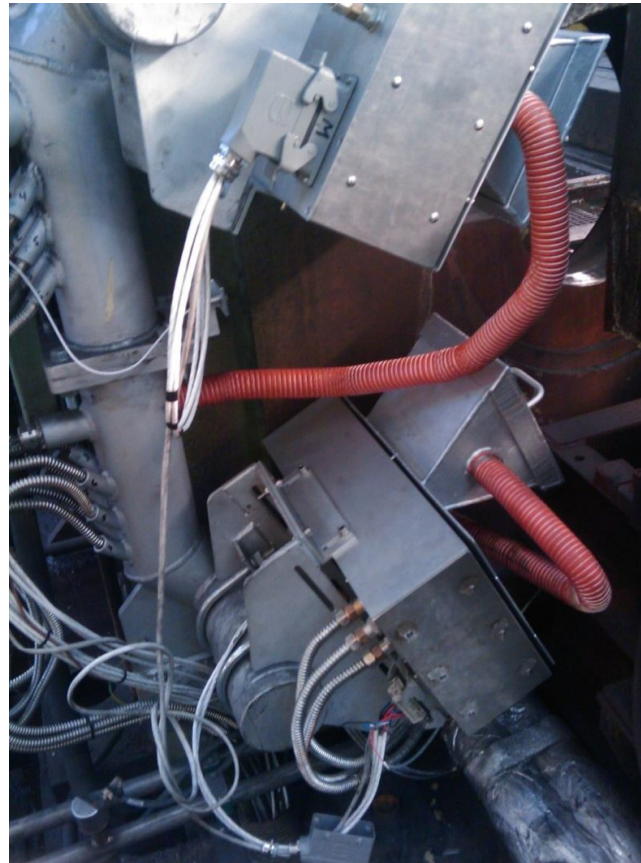
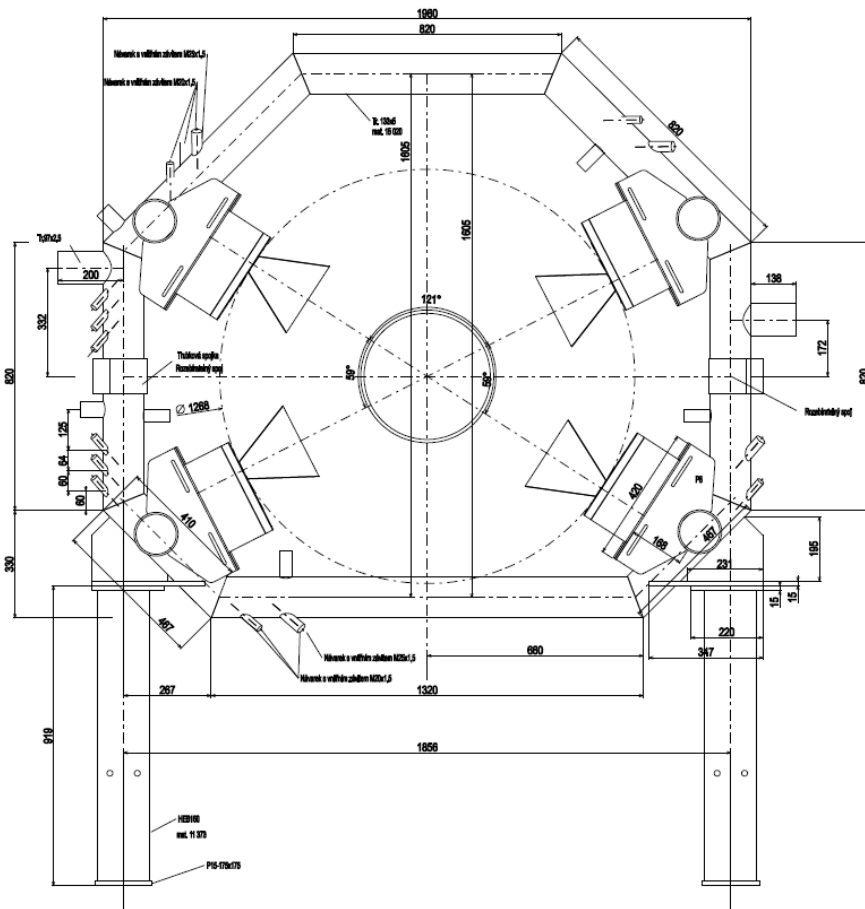

## Loading automation - 3D

**LASE**  
Industrielle Lasertechnik GmbH

Automatic loading and unloading

Product-friendly handling

Recognition of the object size

Accuracies up to  $\pm 0,5\text{mm}$

Accurate position  
collection





## Coil solutions - 2D / 3D

**LASE**  
Industrielle Lasertechnik GmbH

**Position recognition of coils and wagon pits**

**Automatic loading and unloading of wagons**

**Coil-eye measurement**

**Complete measurement**

**Winding quality measurement**

**Damage free set down**

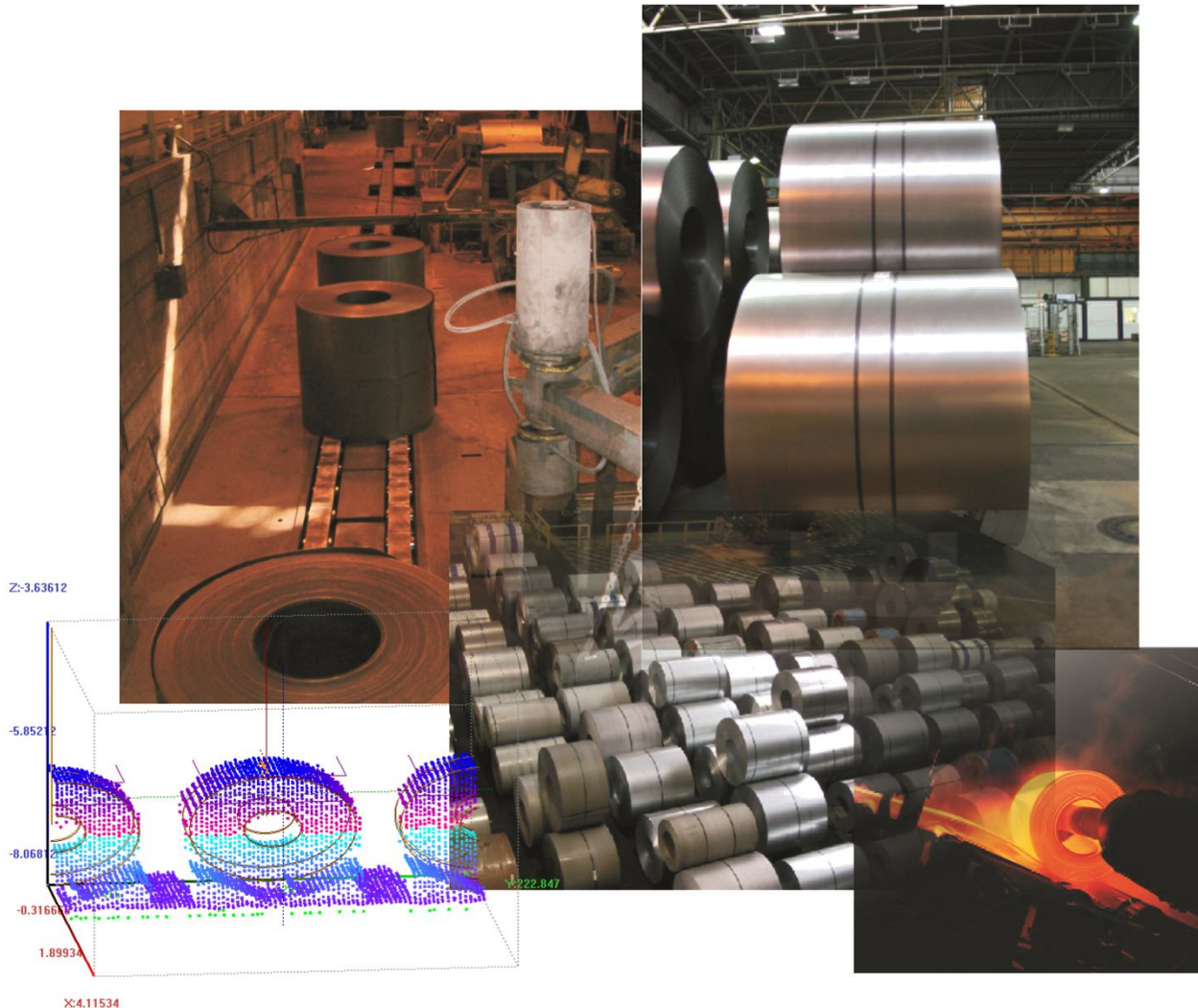

# Automatic coil loading and unloading - 2D / 3D



- Automatic coil handling
- Exact coil recognition
- Coil damage avoidance
- Save labour cost

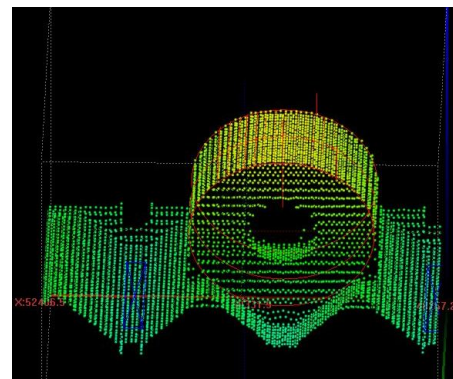



## Automatic coil loading and unloading - 2D / 3D

**LASE**  
Industrielle Lasertechnik GmbH

- Automatic coil handling
- Exact coil recognition
- Coil damage avoidance
- Save labour cost

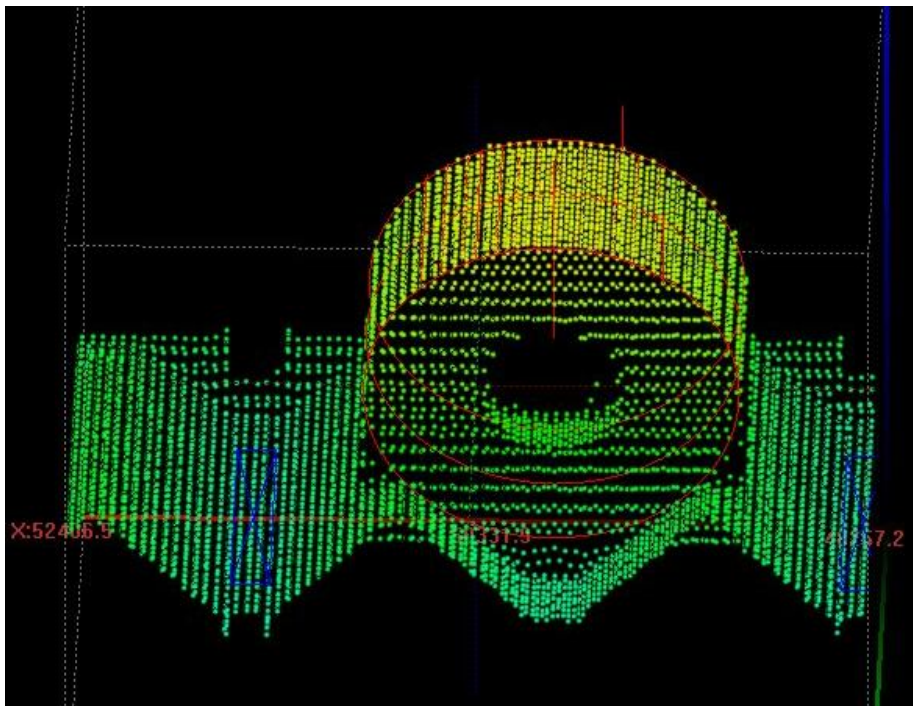

**LASE**  
Industrielle Lasertechnik GmbH

Measurement System for automatic  
coil handling on wagons or transport-racks

# Automatic coil loading and unloading - 2D / 3D

**LASE**  
Industrielle Lasertechnik GmbH

- Fully automatic loading and unloading of wagons
- Exact position recognition of coils and wagons pits
- Product-friendly coil handling
- Robust measuring technique
- Avoidance of damages
- Utilises existing structures

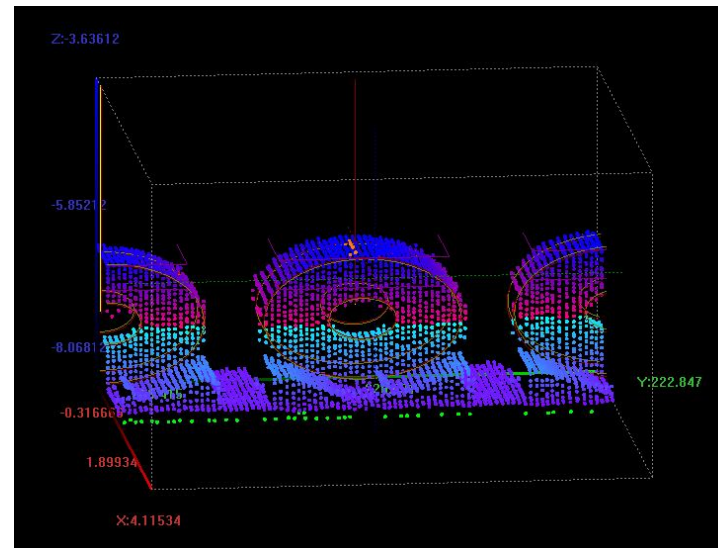
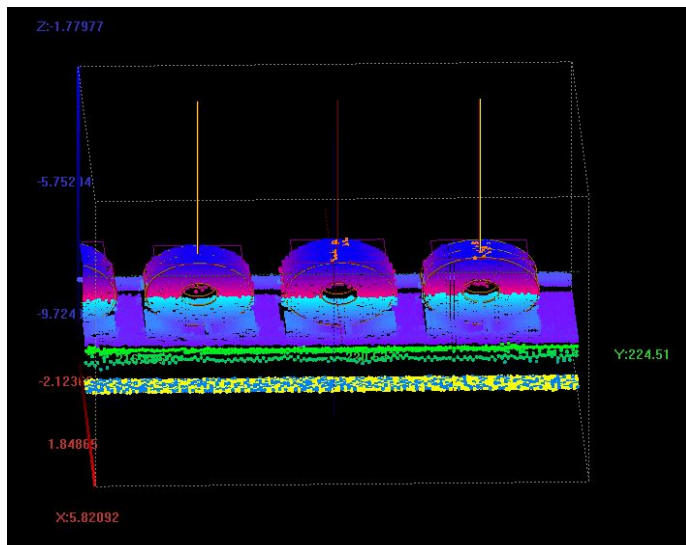
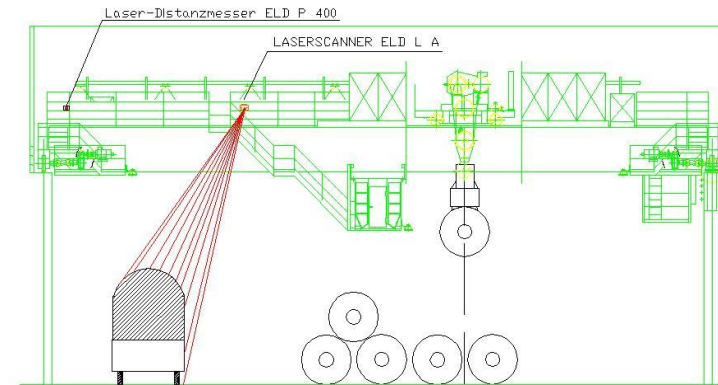

# Automatic Coil Yard - 2D / 3D

**LASE**  
Industrielle Lasertechnik GmbH

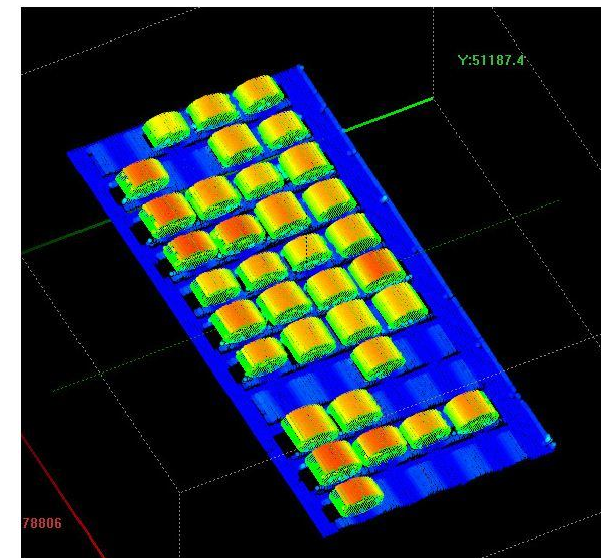
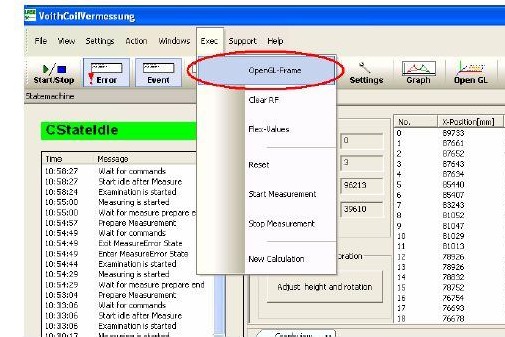
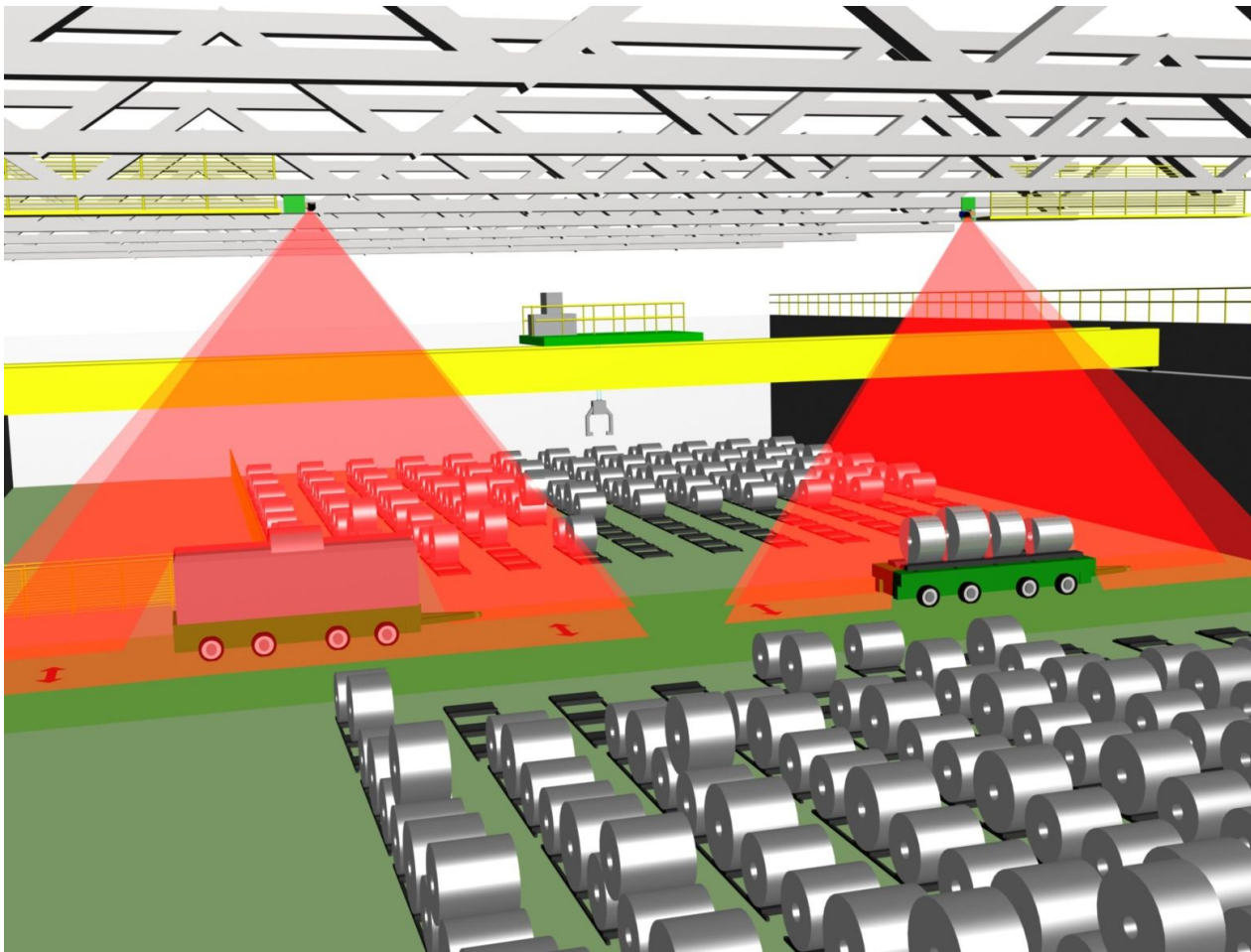



# Automatic Coil Yard - 2D / 3D

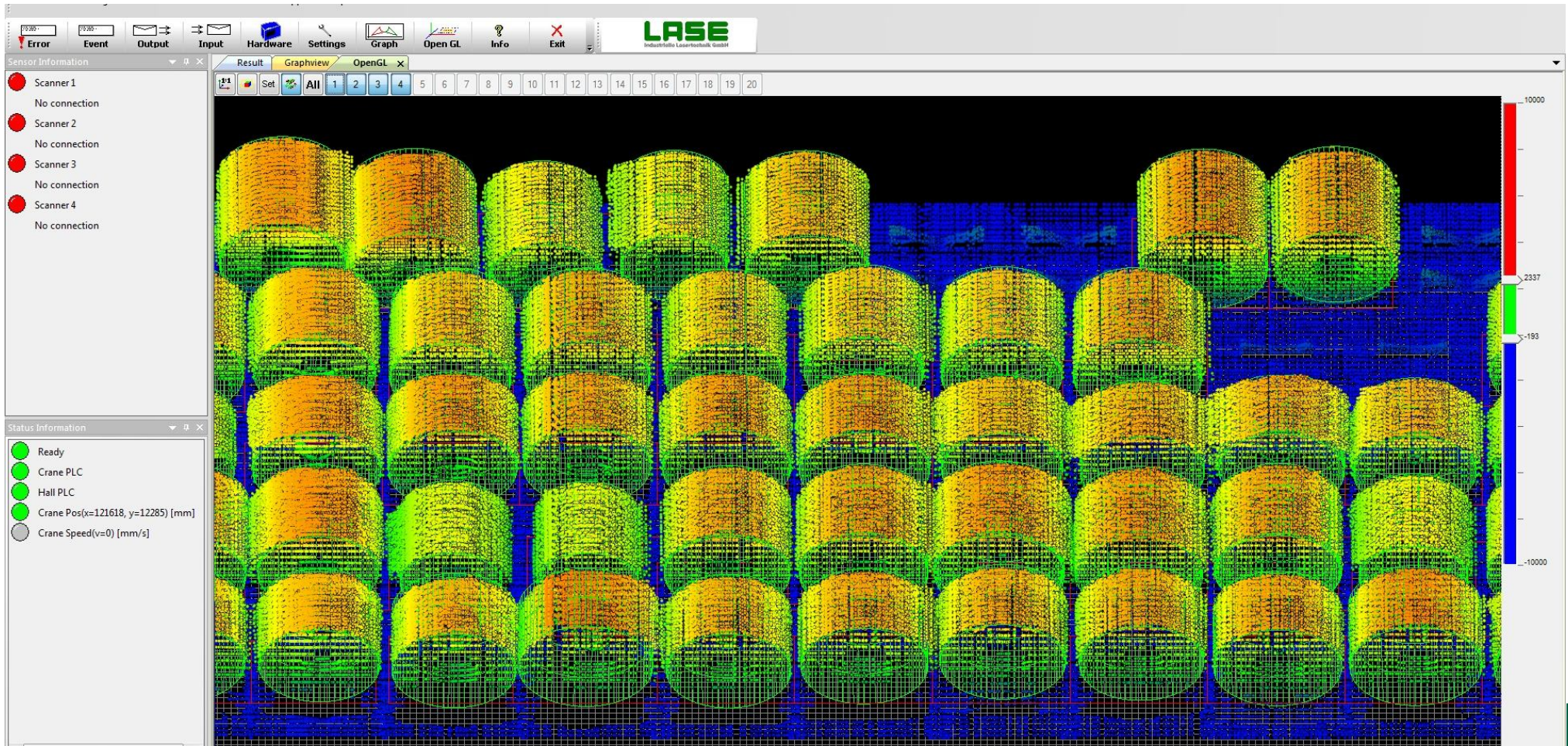



# Automatic Coil Yard - 2D / 3D

**LASE**  
Industrielle Lasertechnik GmbH

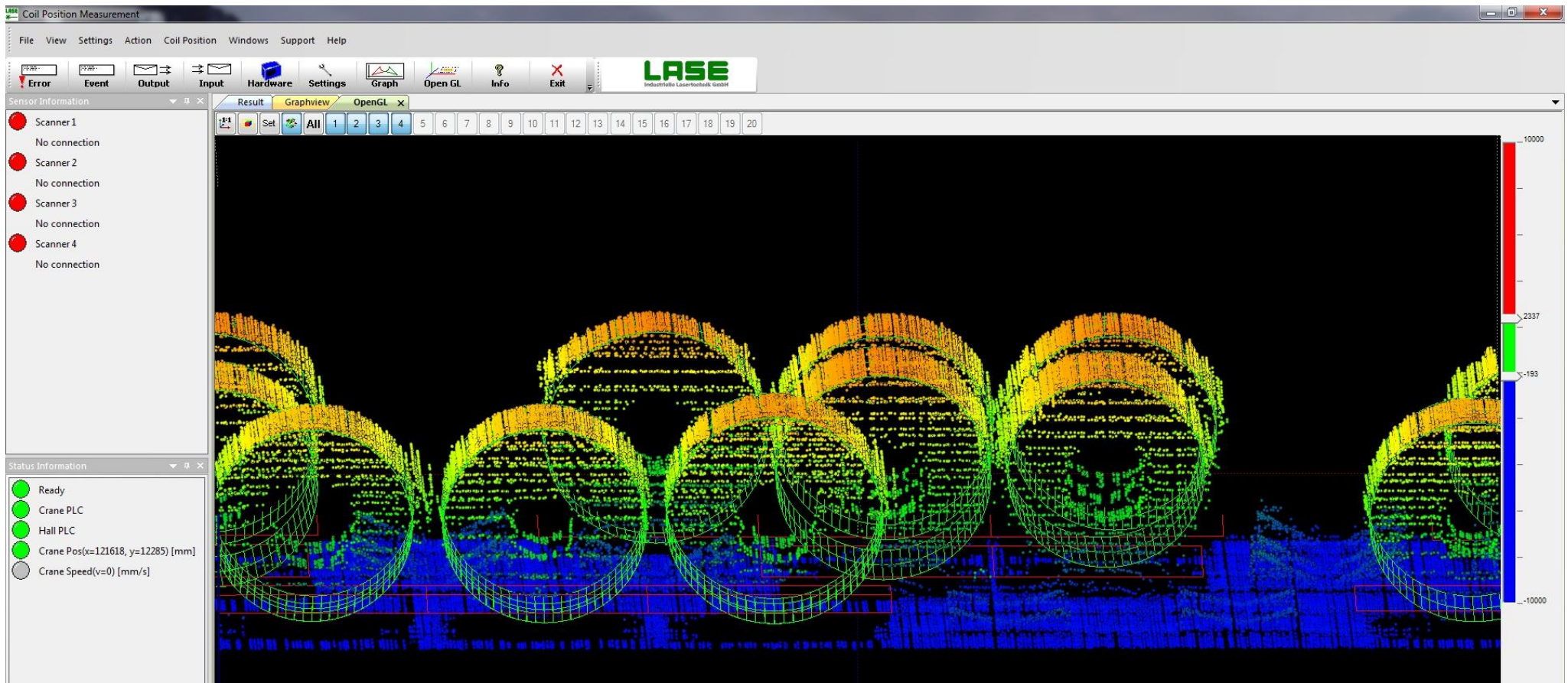

## Automatic Slab Yard - 2D / 3D

**LASE**  
Industrielle Lasertechnik GmbH

- System for automatic crane
- Automatic picking up and putting down of slabs
- Verification of number of slabs in the storage field
- Communication between laser scanners and the warehouse management system

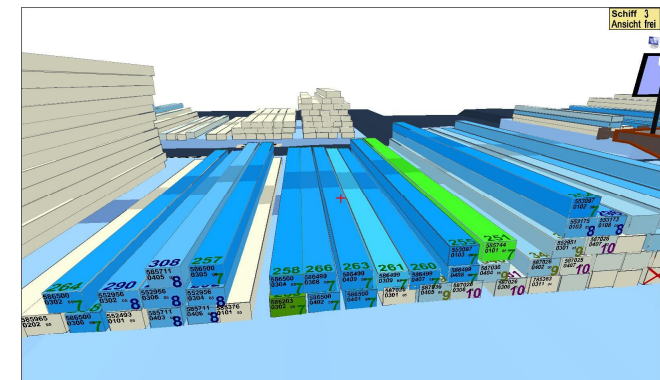

**LASE**  
Industrielle Lasertechnik GmbH

Laser measurement system for  
an automatic working slab yard





# Detection cooling bed - 3D

- high Accuracies
- Fast Measurement
- Function without an operator possible

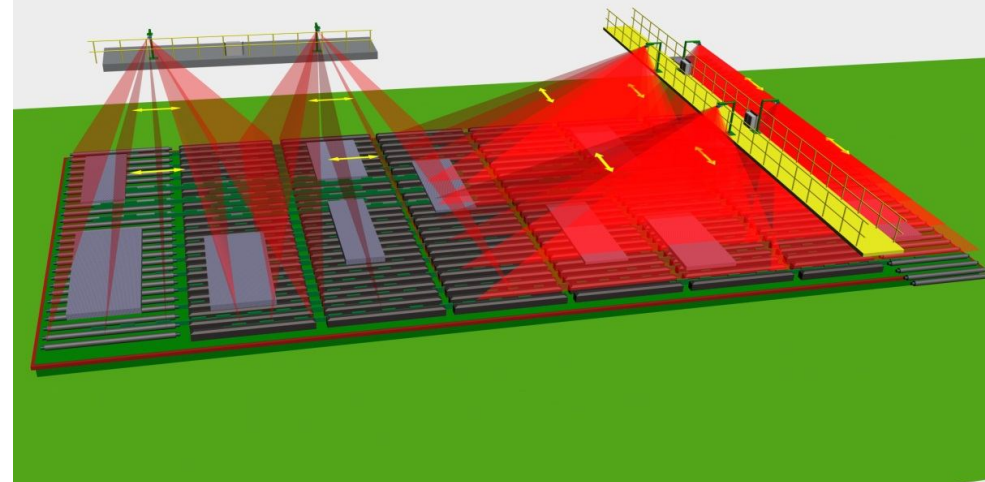
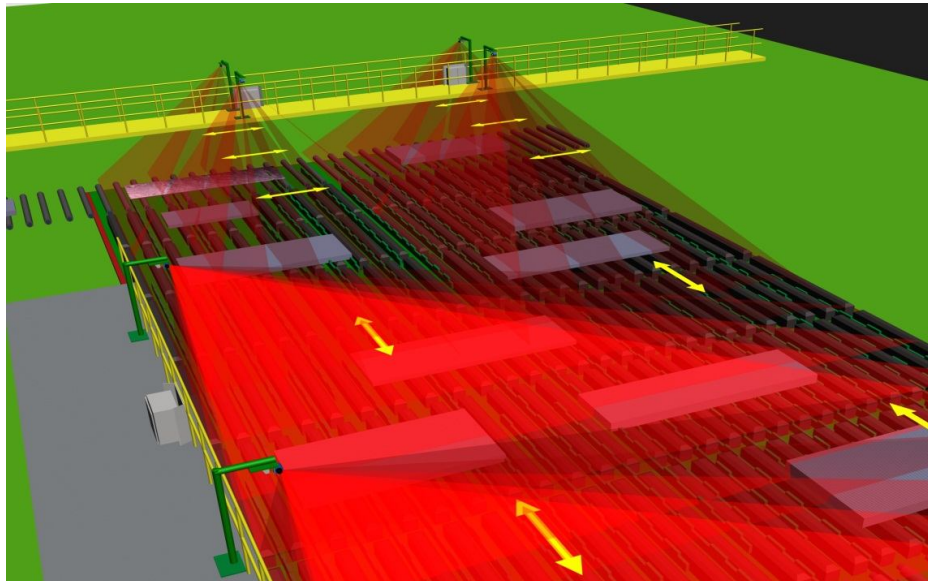

## Sheet Measurement- 3D

- Winding quality control (rough)
- Measurement Diameter
- High Speed Measurement
- Surface with Error detection

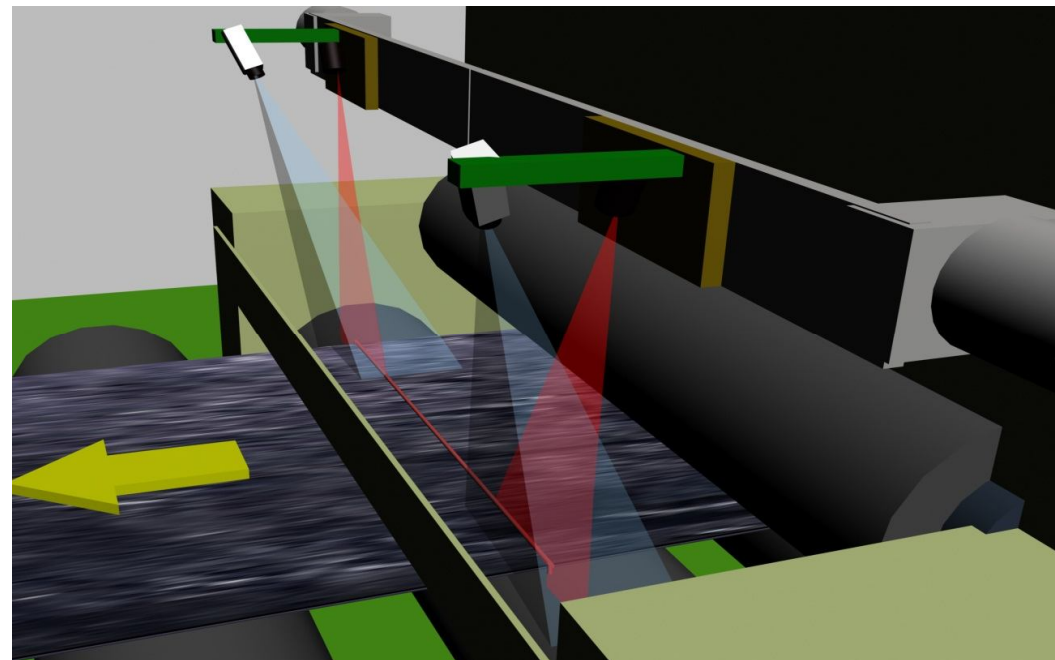
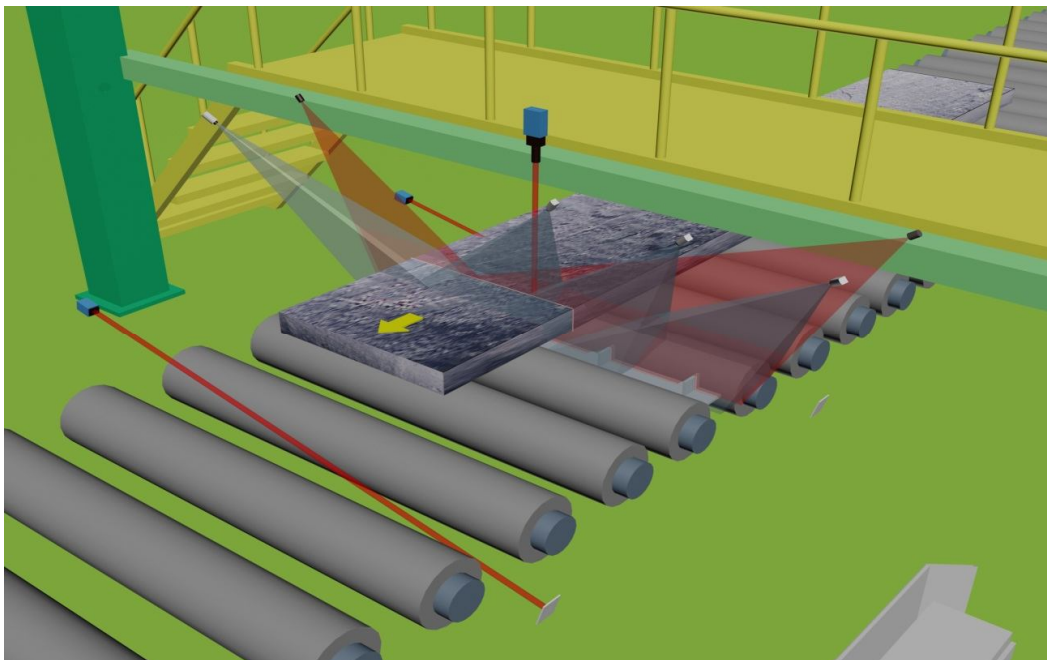



## Coil form detection- 3D

- Winding quality control (rough)
- Measurement Diameter
- High Speed Measurement

**LASE**  
Industrielle Lasertechnik GmbH

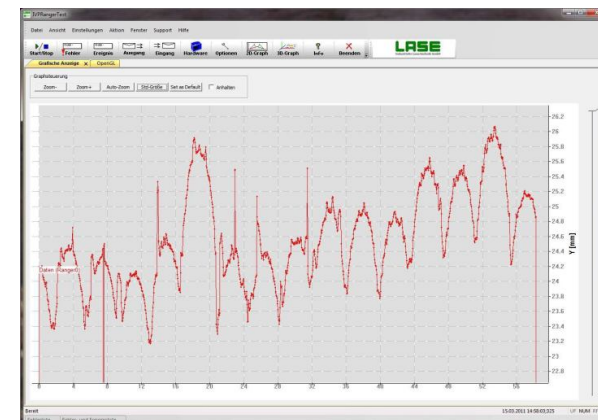
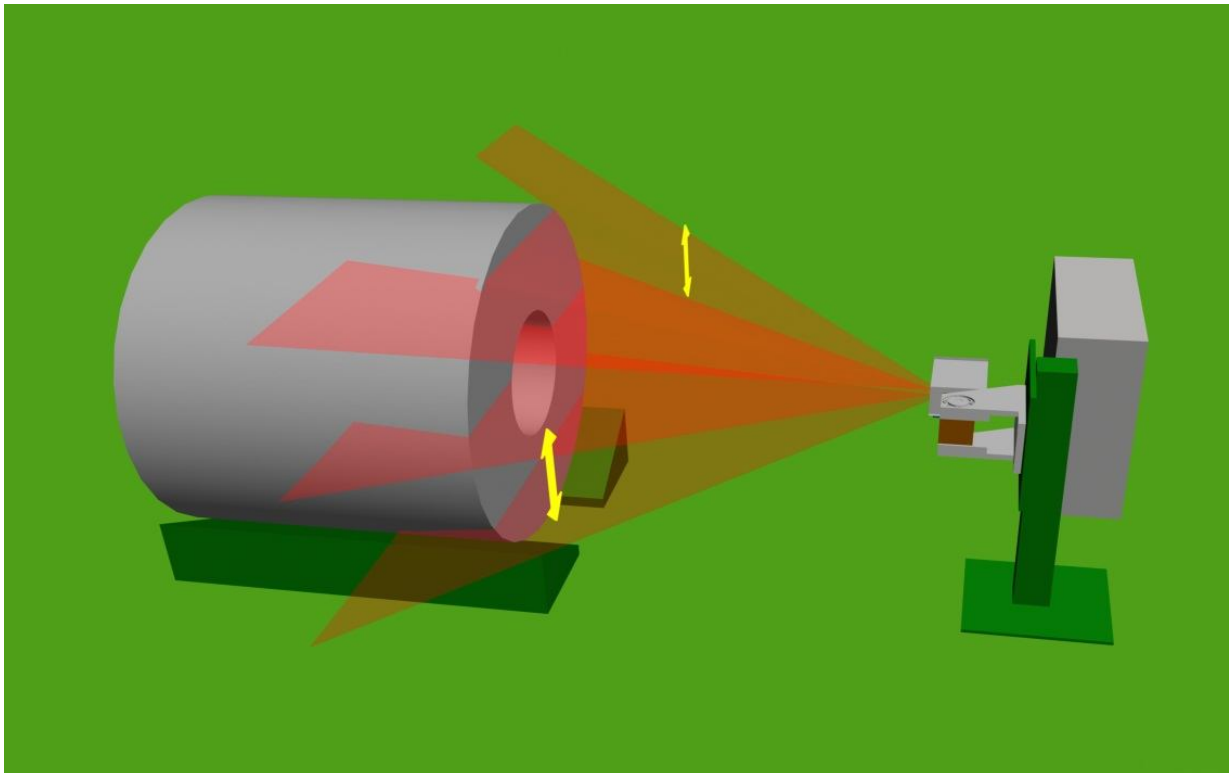

## References

- Thyssen Krupp Steel AG
- Salzgitter AG
- TATA Steel
- Arcelor Mittal
- Baosteel
- Roukella Steel
- Posco
- Usiminas
- Gerdau

*Only a small part of our reference list.*

**We can say:**

For any case of contactless measurement the company **LASE** is a good choice!

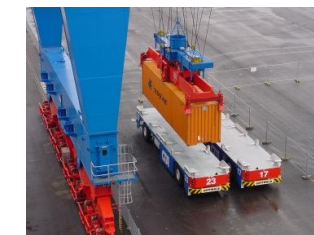
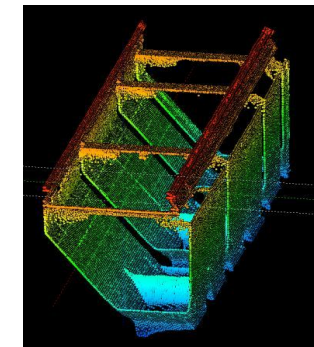
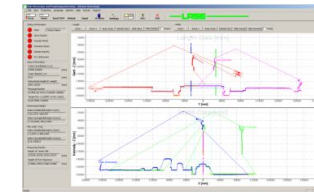
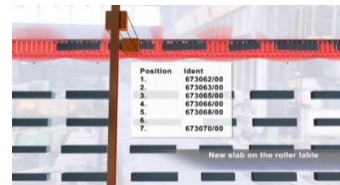
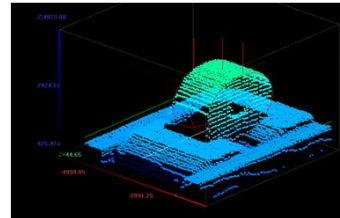

**LASE**  
Industrielle Lasertechnik GmbH





YOUR APPLICATION OF TODAY WITH  
OUR TECHNOLOGY OF TOMORROW